

RoHS Compliant

REV.	Revision note	Date	Signature	Checked
1.0	Release to product	17/07/26	Pillar	

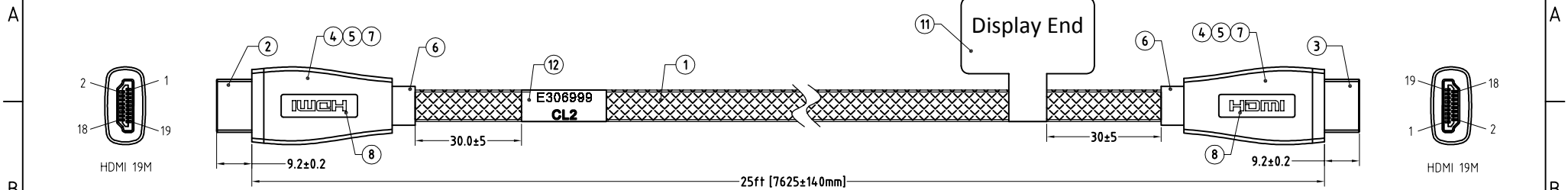

※ Note
 1) Copper foil under the over-mould
 2) Supports 4K/30Hz,10.2Gbps bandwidth

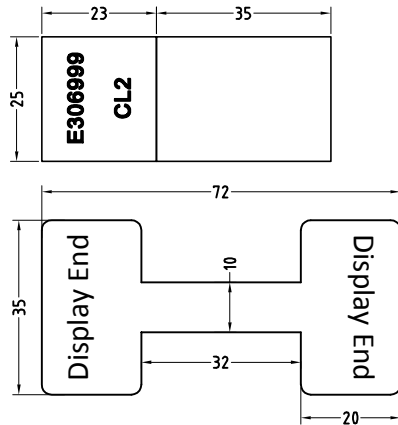
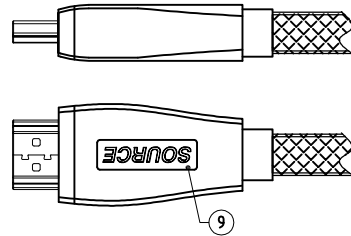

Wire Details

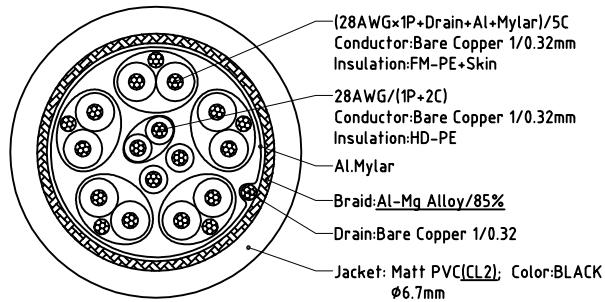

PIN ASSIGNMENT

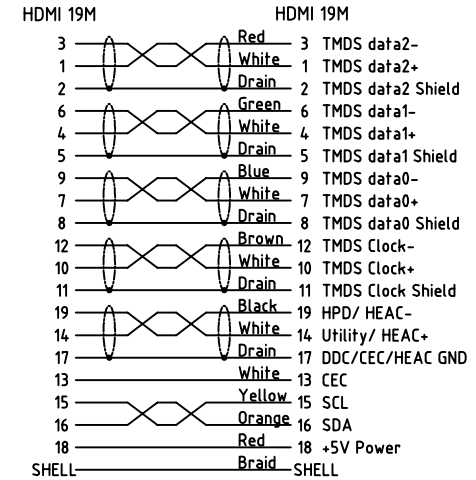

NO.	PART NAME	SPEC DESCRIPTION	PART P/N	REMARK
12	Label	Size:72*35mm,Black lettering with white background,Print "E306999..." logo	xxxx	
11	Label	Size:72*35mm,Black lettering with white background,Print "Display End" logo	xxxx	
10	Badge	Aluminum badge,Print "SINK" logo	xxxx	
9	Badge	Aluminum badge,Print "SOURCE" logo	xxxx	
8	Badge	Aluminum badge,Print "HDMI" logo	xxxx	
7	Shell	Zinc alloy shell,Twin set,Front body gold plated,Back body silver plated	xxxx	
6	Overmold	PVC,45Pa,Black	xxxx	
5	Copper Foil	Copper Foil	xxxx	
4	Inermold	PE,Low density	xxxx	
3	Conn	HDMI A/M,Pin G/F,Black LCP Insulation,Shell(Copper) gold plated(G/F),with PCBA(RedMere PRA1700)	xxxx	
2	Conn	HDMI A/M,Pin G/F,Black LCP Insulation,Shell(Copper) gold plated(G/F),Solder type	xxxx	
1	Cable	UL20276 (28#AD/1P+D+A+M)/5C+28#AD/(1P+2C)+A+D+B(Al-Mg/85%),0D6.5mm,BLACK PVC Jacket, with black/white braid mesh	xxxx	

Mould number:	Customer: M018UA	Customer P/N: HA-HHIC-25	Article No./ HL-GC-001			
	Designed by: Pillar	Checked by:	Approved by	File number: D-1060	Date: 17/07/26	
				Name: HDMI Cable,28AWG,with Ethernet,with RedMere	Scale: none	Unit: mm
Packing file:	This drawing contains information that is proprietary to Hallink Electronics Limited incorporated and should not be used without written permission			P/N: HC.HH112728-1060	Edition: 1.0	Sheet: 1/1 A3